

# DIE CHANGE

ISMR explores die change issues with Serapid

## ISMR SAYS:

“Repeated die changes increase downtime and can result in damage to expensive dies”

Serapid, a quick die change specialist, plans to increase turnover by 25% per annum. Hervé Brebion, Export Sales QDX, speaks to ISMR

# RAPID DIE CHANGE



Hervé Brebion,  
Export Sales QDX  
at Serapid

**ISMR: Please outline how Quick Die Change can be a valuable tool for meeting increasing demands for lower cost and higher quality parts.**

**HB:** Repeated die changes increase downtime and can result in damage to expensive dies. Repetitive stress injuries and the risk of accidents increases. Our Quick Die eXchange program (QDX) covers the entire process of die change: clamping, positioning and transporting. The choice of components is optimized to make the process of die change quick, safe and repeatable and provides a measurable return on investment.

**ISMR: What are the advantages and benefits for a sheet metal manufacturer of using your quick die change solutions? How are they different from other solutions on the market today?**

## AT A GLANCE

Serapid was created in 1972 in Normandy, France. From the beginning, the company was quick die change-oriented, manufacturing and selling tools that could clamp dies quickly and securely.

After a few years, the company added new roller bars and die carts to its range of products to meet the demand for new die transportation and positioning tools. By adding its patented rigid chain technology to its products, Serapid created a new kind of die cart and GPO trucks allowing the transportation, change and positioning of dies from storage areas into the press bed using a single piece of equipment.

With 82 people working internationally for Serapid, in the quick die change, industry and theatre sectors, the company has achieved sustained and profitable growth and is planning to continue this growth worldwide.

**HB:** Serapid's Quick Die eXchange program eliminates the problems mentioned here, dramatically reducing downtime and increasing overall efficiency and safety of both the press equipment and operators.



Above: Die carts on rails  
Right: Motorised bolster extensions

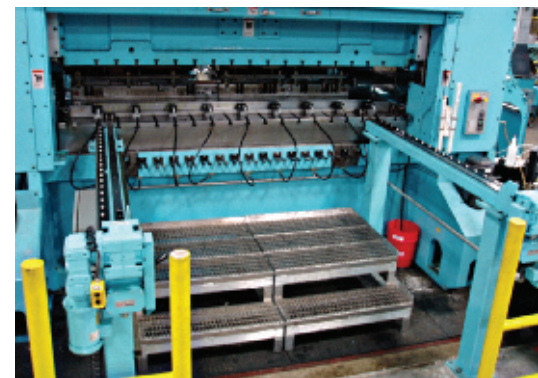

Our solutions are different because we use our rigid chain technology in most of our transfer and positioning QDX solutions. The Rigid Chain is a telescopic mechanical actuator that is flexible in one direction and forms a steel beam in the other direction.

Serapid is one of the few total solution providers; with clamps, transfer and transport all manufactured by Serapid. The use of the Rigid Chain gives the user options that are not be available with other technologies such as the ability to push dies across swing aside bolster extensions. >>

# DIE CHANGE

ISMR explores die change issues with Serapid

**“ We plan to launch a new range of GPO driver-operated trucks to meet the need for more flexibility in Quick Die eXchange ”**



Above: GPO truck with die  
Right: Double die cart

**» ISMR: Please outline current metal pressing trends and die change usage in sheet metal markets? Have you noticed any regional trends in different parts of the world?**

**HB:** We have noticed that the market for metal pressing tends to move towards Eastern Europe, Asia and North Africa. This trend seems to follow the strategy of the automotive industry.

**ISMR: What are your main objectives and targets over the next few years? How do you intend to achieve them?**

**HB:** Our main objective is to continue to grow worldwide and increase our turnover by 25% per annum. We are currently a small to medium sized company with plants in France and in the USA and subsidiaries, representative offices and agents in France,

USA, Germany, UK, China, Italy, Northern Europe and Australia. We have a truly worldwide customer base.

In February 2010, we opened a new representative office in China, initially for our theatre sector but this will probably expand to handle our other industry sectors. We intend to continue our growth to meet the increasing demand across all our operational divisions.

**ISMR: How many customers do you have worldwide? Please outline Serapid's successes and achievements over the last two years.**

**HB:** Over the years, in our QDX sector, we have built up a customer base numbering many thousands of clients worldwide. The last two years were disappointing because of the state of the economy.

We sold several Push-Pull Systems specifically to improve the ergonomics of the press environment in a number of plants. In addition to this, we introduced a new product

(motorized bolster extensions) in line with our continuing commitment to product development.

**ISMR: Serapid also specializes in the design and manufacture of linear transfer solutions. Please outline any trends you see in industrial markets and the benefits for users of your solutions?**

**HB:** Many customers are looking for an alternative to hydraulic and screw jack actuators and are considering Serapid because we produce mechanical actuators that are highly reliable, work in challenging environments and offer long strokes and heavy load capabilities. The nature of the product allows it be used where lack of space precludes the use of other technologies.

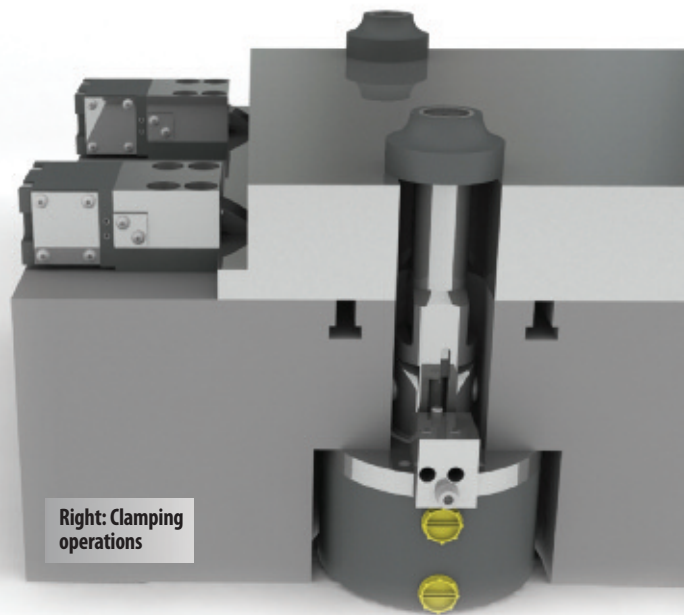

Right: Clamping operations

**ISMR: Do you have plans to launch any new products over the next year? Please elaborate.**

**HB:** We plan to launch a new range of GPO driver-operated trucks to meet the need for more flexibility in Quick Die eXchange. We have decided to increase the capabilities of our current GPO driver-operated trucks by offering a larger range of options, making this QDX solution more flexible and we have improved its handling. We will present this new range of trucks at EuroBLECH 2010 in Germany.

**ISMR: Thank you for your time.**

## CONTACT

**HERVÉ BREBION**

Export Sales QDX  
QDX SERAPID GROUP  
SERAPID S.A.S

453, route de Dieppe, 76660 Londinières, France  
E-mail: qdx@serapid.com Website: www.serapid.com  
Tel: +33 2 35 93 82 82 Fax: +33 2 35 94 10 93

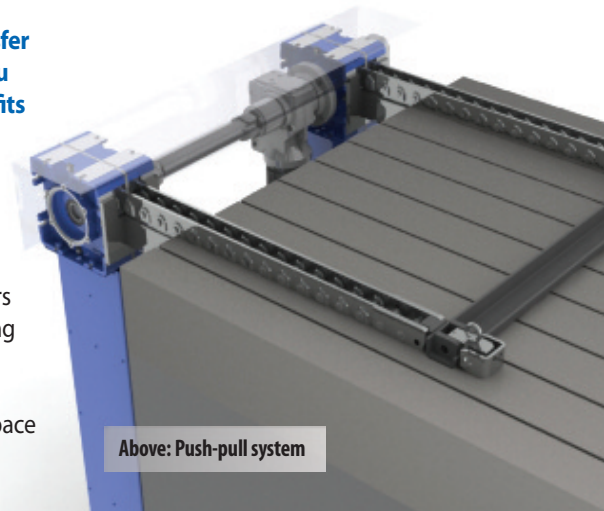

Above: Push-pull system